

MATERIAL	REV.	DESCRIPTION	DATE	DR.	APVD.
OIL DRILL ROD	A	ISSUED NEW REV W/ SW	03/21/2019	YS	DS

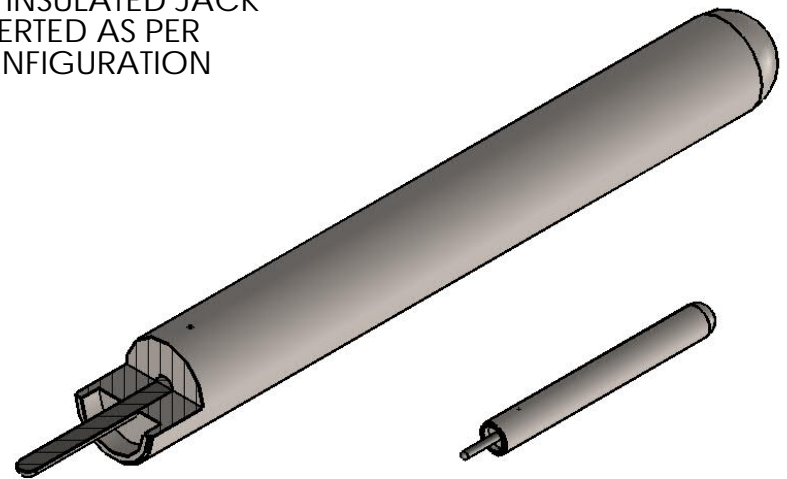

INSTALLATION PROCEDURE

1. DRILL A HOLE IN THE CHASSIS WITH RECOMMENDED SIZE FOR CHOSEN JACK PART NUMBER.
2. SIMPLY CENTER JACK IN TOOL OVER CHASSIS HOLE AND WITH PRESSURE APPLIED. THE PRESS-FIT JACK SLIPS INTO THE HOLE FOR A RIGHT, PERMANENT, TROUBLE FREE INSTALLATION.

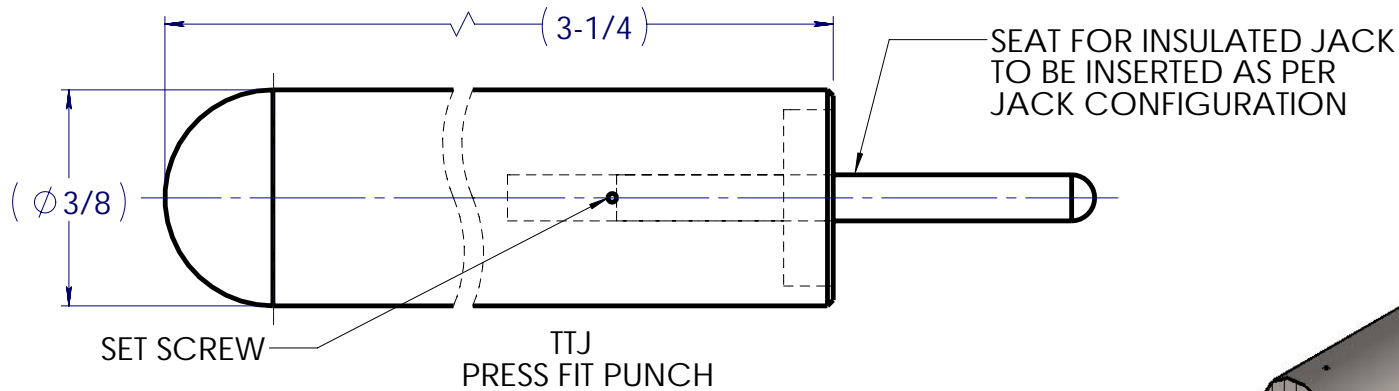
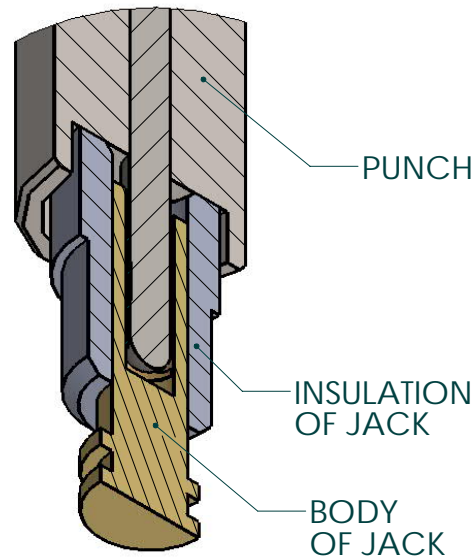
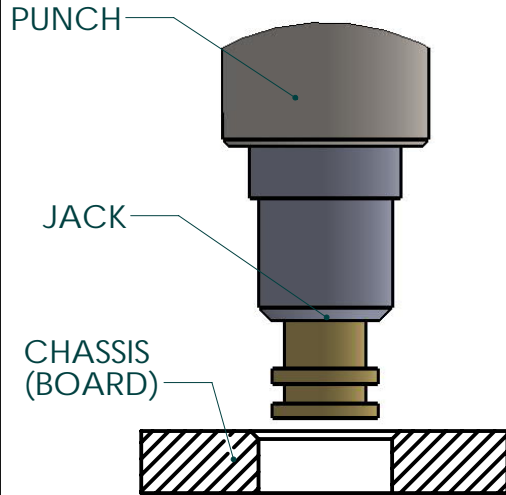

UNLESS OTHERWISE SPECIFIED:
DIMENSIONS ARE IN INCHES

TOLERANCES:
TWO PLACE DECIMAL ± 0.01
THREE PLACE DECIMAL ± 0.010
FRACTIONAL $\pm 1/64$
ANGULAR $\pm 5^\circ$

PROPRIETARY AND CONFIDENTIAL
THE INFORMATION CONTAINED IN THIS DRAWING IS THE SOLE PROPERTY OF CONCORD ELECTRONICS INC. ANY REPRODUCTION IN PART OR AS A WHOLE WITHOUT THE WRITTEN PERMISSION OF CONCORD ELECTRONIC INC. IS PROHIBITED.

CONCORD ELECTRONICS, INC.

TITLE: GENERIC DRAWING OF
INSTALLATION TOOL FOR
PRESS FIT (TTJ TYPE),
HAND OPERATED

DWG. NO.

TTJ

REV

A



WEIGHT:

SCALE: NTS