

MATERIAL	REV.	DESCRIPTION	DATE	DR.	APVD.
OIL DRILL ROD	A	ISSUED	04/23/2019	YS	DS

UPPER TOOL (SNAP-IN ELLIPTICAL PUNCH)
IS DESIGNED TO PROPERLY
INSTALL TERMINAL
ONTO BOARD

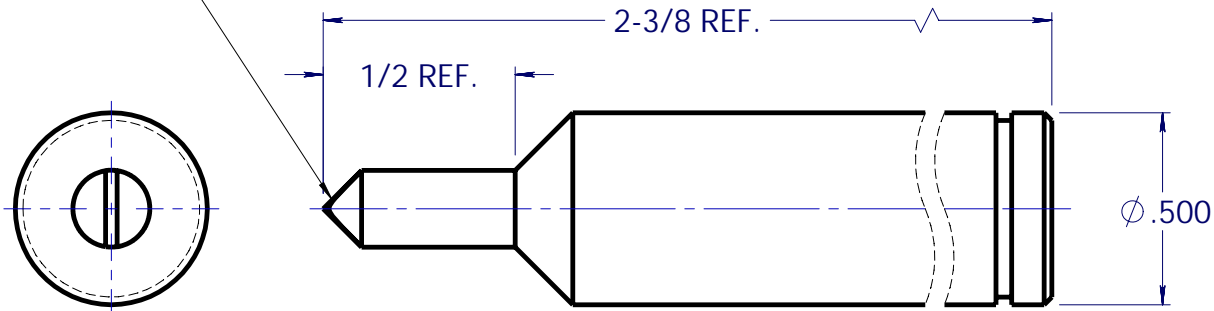

THXP - PUNCH

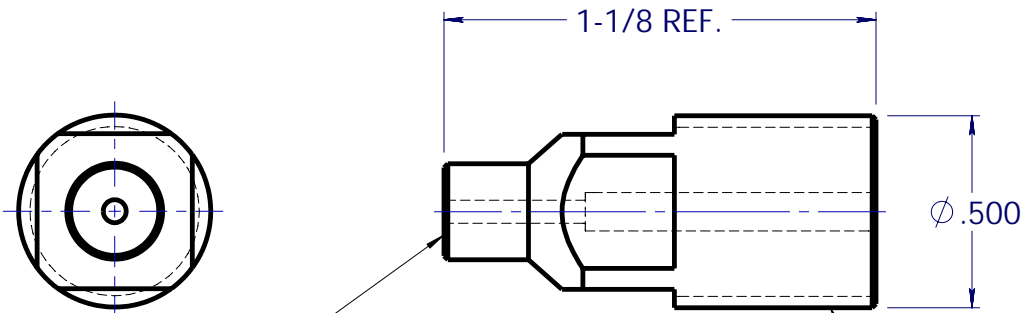
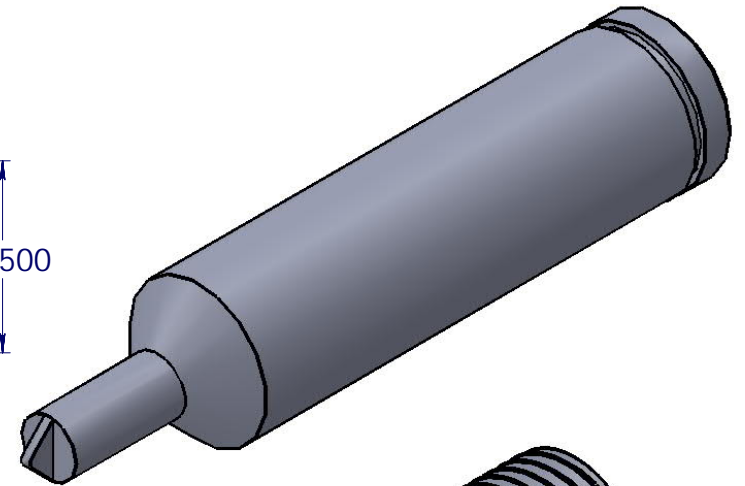

THA - ANVIL

1/2-24 THREAD

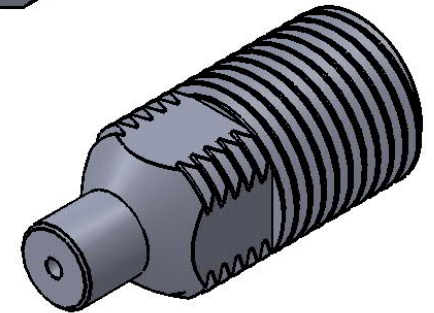

LOWER TOOL (THREADED ANVIL)
IS DESIGNED TO HOLD
TERMINAL IN PROPER POSITION
DURING INSTALLATION OPERATION

UNLESS OTHERWISE SPECIFIED:

DIMENSIONS ARE IN INCHES

TOLERANCES:

THREE PLACE DECIMAL ±0.010
FRACTIONAL ±1/64

PROPRIETARY AND CONFIDENTIAL

THE INFORMATION CONTAINED IN THIS DRAWING IS THE SOLE PROPERTY OF CONCORD ELECTRONICS INC. ANY REPRODUCTION IN PART OR AS A WHOLE WITHOUT THE WRITTEN PERMISSION OF CONCORD ELECTRONIC INC. IS PROHIBITED.



TITLE:
GENERIC DRAWING OF INSTALLATION
TOOLS FOR ELLIPTICAL SWAGING (THA
& THXP TYPES), ARBOR PRESS
OPERATED

DWG. NO. **THA & THXP** REV **A**

REV.	DESCRIPTION	DATE	DR.	APVD.
A	ISSUED	04/23/2019	YS	DS

ELLIPTICAL SWAGE INSTALLATION PROCEDURE FOR TERMINALS

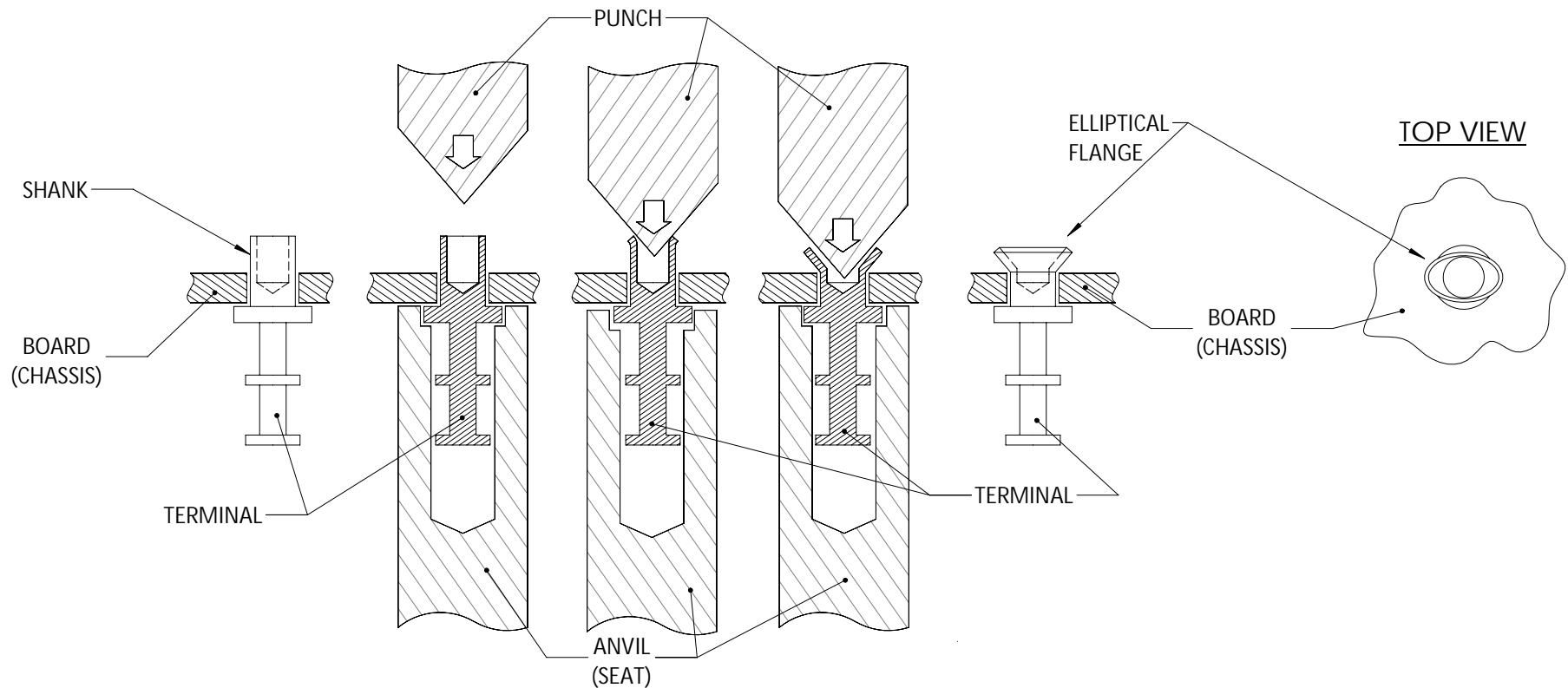

1. THE NAME , "ELLIPTICAL SWAGE" FAIRLY WELL DESCRIBES WHAT IS HAPPENING TO THE PART. THE ELLIPTICAL SWAGING OPERATION FORMS THE LIPS OF THE SHANK INTO A ELLIPTICAL SHAPE. THE TOOL THAT DOES THE ACTUAL FORMING IS CALLED THE "ELLIPTICAL PUNCH". THE TOOL THAT SUPPORTS THE TERMINAL WHILE SWAGING IS BEING DONE IS CALLED THE "ANVIL" (ALSO SOMETIMES CALLED THE "SEAT")
2. PLACE PROPER CONCORD'S ANVIL AND PUNCH INTO ARBOR PRESS AND ALIGN TOOLS PRIOR SWAGE FORCE.
3. DRILL A HOLE IN THE BOARD THAT IS JUST LARGE ENOUGH FOR THE SHANK OF THE TERMINAL TO PASS THROUGH, BUT NOT LARGE ENOUGH FOR THE SHOULDER TO PASS THROUGH (SEE INDIVIDUAL PART SPECIFICATIONS FOR RECOMMENDED HOLE SIZE).
4. PLACE A TERMINAL INTO THE ANVIL AND BOARD AS SHOWN.
5. PRESS TERMINAL USING PUNCH TOOL UNTIL LIP OF SHANK, WHICH EXTENDS PASSED THE FACE OF THE BOARD IS FORMED TO ELLIPTICAL SHAPE.
6. RASE THE PUNCH TOOL. TERMINAL IS NOW PERMANENTLY IN PLACE.

UNLESS OTHERWISE SPECIFIED:

DIMENSIONS ARE IN INCHES

TOLERANCES:

THREE PLACE DECIMAL ± 0.010
 FRACTIONAL $\pm 1/64$

PROPRIETARY AND CONFIDENTIAL

THE INFORMATION CONTAINED IN THIS DRAWING IS THE SOLE PROPERTY OF CONCORD ELECTRONICS INC. ANY REPRODUCTION IN PART OR AS A WHOLE WITHOUT THE WRITTEN PERMISSION OF CONCORD ELECTRONIC INC. IS PROHIBITED.



TITLE:
 GENERIC DRAWING OF INSTALLATION TOOLS FOR ELLIPTICAL SWAGING (THA & THXP TYPES), ARBOR PRESS OPERATED

DWG. NO.

THA & THXP

REV

A



PAGE: 2 OF 2

SCALE: NTS