

DRAWING NUMBER:	09-9128-1-XXXX
PRODUCT GROUP:	BANANA PLUGS, JACKS AND PHONE TIPS
SUB-GROUP:	INSULATED BANANA JACKS
DESCRIPTION:	INSULATED STANDARD BANANA PANEL JACK

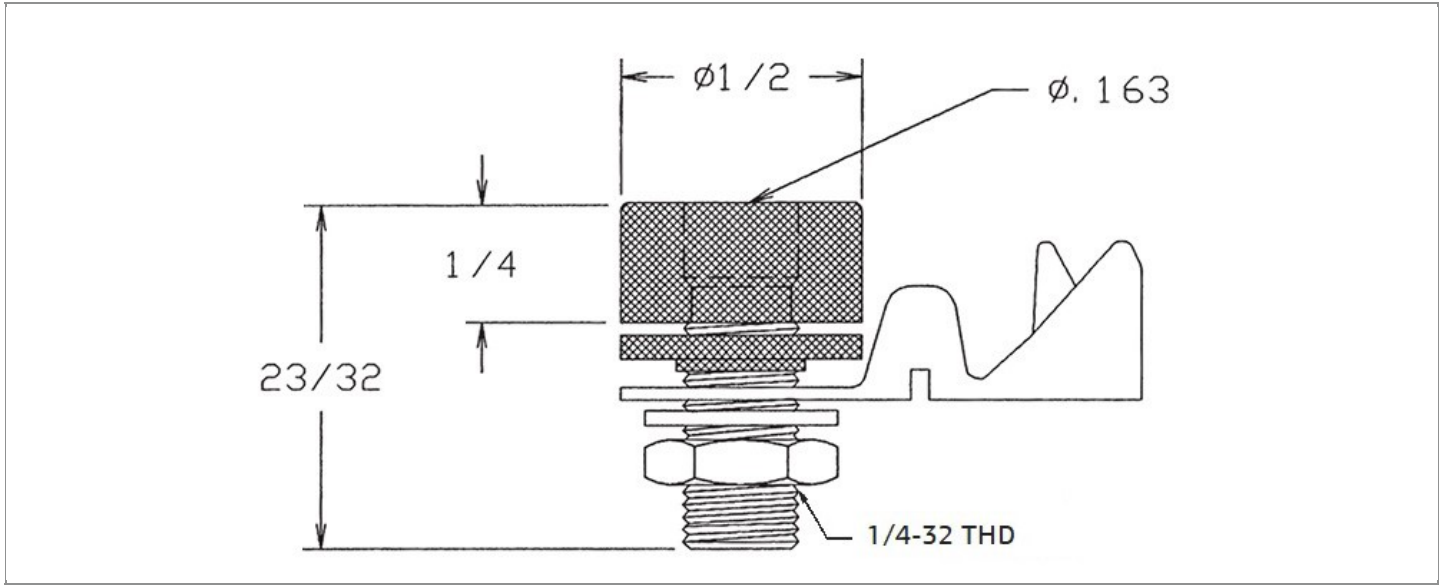

ACCEPTS PIN / PLUG / JACK SIZE	OVERALL LENGTH	MIN. HOLE DEPTH	BOARD / PANEL MOUNTING METHOD
STANDARD BANANA PLUG	0.719"	0.719"	THREAD MOUNT (1/4-32 NUT)
MOUNTING HOLE SIZE	DRILL SIZE	BOARD / PANEL THICKNESS	
0.312" ± 0.002	5/16"	UP TO 3/8"	

PART NO. STRUCTURE:

09-9128	-	1	-	XX	XX
PART SERIES		DIMENSION		FINISH	INSULATION COLOR

MATERIAL OPTIONS:

09-9128-1-XXXX

COMPONENT	MATERIAL	MATERIAL AND SPECIFICATION
BODY	BRASS	BRASS
JACK SPRING	N/A	N/A
INSULATION*	NYLON	NYLON
PIN	N/A	N/A
NUT	BRASS	BRASS
WASHER	PHOSPHOR BRONZE	PHOSPHOR BRONZE
LUG	COPPER	COPPER

*For Insulation color, please see INSULATION COLOR OPTIONS on Page 2

FINISH - PLATING OPTIONS:

09-9128-1-XXXX

FINISH CODE	COMPONENT	FINISH	FINISH AND SPECIFICATION
02	BODY	NICKEL	NICKEL
	JACK SPRING	N/A	N/A
	PIN	N/A	N/A
	NUT	NICKEL	NICKEL
	WASHER	NICKEL	NICKEL
	LUG	ELECTRO-TIN	ELECTRO-TIN

INSULATION COLOR OPTIONS:

09-9128-1-XXXX

INSULATION COLOR	BLACK	RED
COLOR CODE NO.	10	12

TOLERANCES:*

DECIMAL	FRACTIONAL	ANGULAR	DRAWING ORIENTATION DATE	LAST MODIFICATION DATE
± 0.010	N/A	N/A	9/6/1996	4/1/2017

*All dimensions are in inches.

RoHS COMPLIANCE:

09-9128-1-02XX

PART NUMBER	RoHS COMPLIANT
09-9128-1-0210	YES
09-9128-1-0212	YES

NOTES:

DATASHEET NOTES
ACCEPTS STANDARD BANANA PLUG. MOUNTS IN ROUND HOLE IN PANEL. NUT PART NUMBER: 701-7416-02. INTERNAL TOOTH LOCKWASHER PART NUMBER: 701-7705. LUG PART NUMBER: 707-1754.
INSTRUCTION NOTES
SUPPLIED WITH: MOLDED NYLON CAP AND WASHER, NICKEL PLATED BRASS HEX NUT (1/4-32 x 11/32" x 5/64"), NICKEL PLATED PHOSPHOR BRONZE INTERNAL TOOTH LOCKWASHER (1/4"), AND ELECTRO-TIN PLATED COPPER SOLDER LUG (1/4").