

DRAWING NUMBER:	1125-45M-XXXXZ
PRODUCT GROUP:	TERMINALS
SUB-GROUP:	MILITARY INSULATED TERMINALS
DESCRIPTION:	PTFE INSULATED DOUBLE TURRET TERMINAL

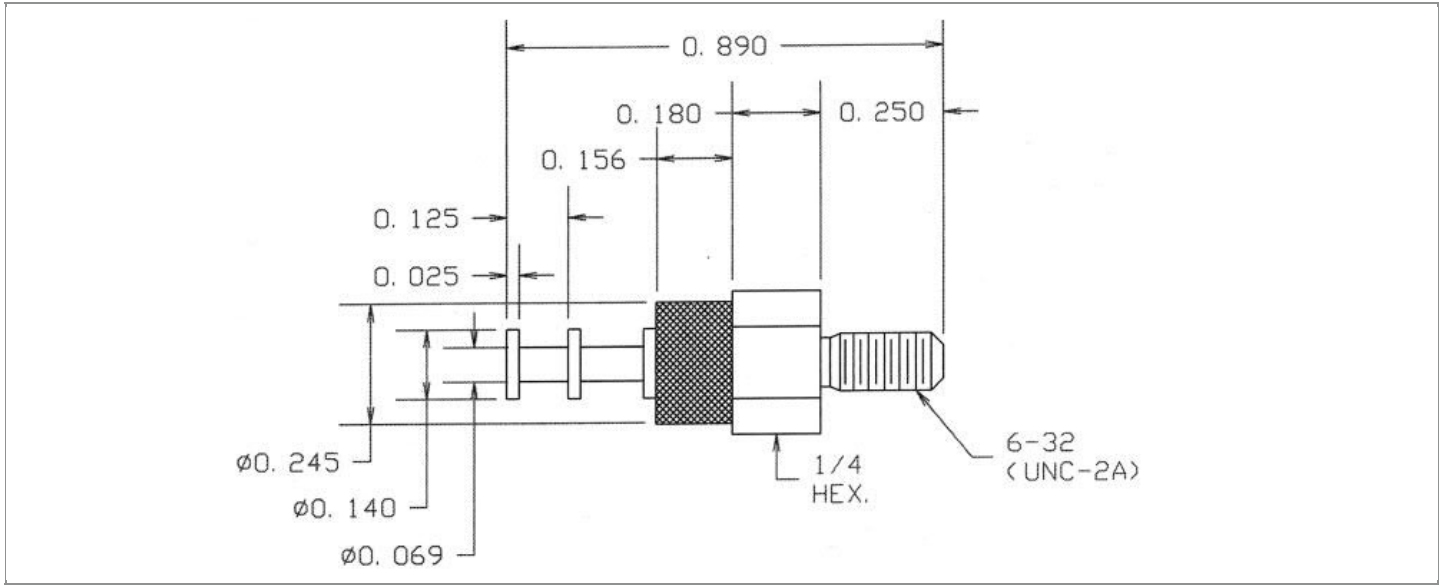

PIN DIAMETER	OVERALL LENGTH	MOUNTING ORIENTATION	BOARD / PANEL MOUNTING METHOD
N/A	0.890"	VERTICAL	THREAD MOUNT (6-32 NUT)
BOARD / PANEL THICKNESS	MOUNTING HOLE SIZE	DRILL SIZE	FEED THRU COMBINATION
UP TO 1/8"	0.144" ± 0.002	#27	N/A

PART NO. STRUCTURE:*

1125	-	45M	-	XX	XX
PART SERIES		DIMENSION		FINISH	INSULATION COLOR

*If applicable, "Z" at the end of a PART NO. STRUCTURE indicates TERMINAL MATERIAL TYPE.

MATERIAL OPTIONS:

1125-45M-XXXXZ

COMPONENT	MATERIAL	MATERIAL AND SPECIFICATION
TERMINAL	PHOSPHOR BRONZE	PHOSPHOR BRONZE PER ASTM B139, ALLOY C54400
BASE/METAL SLEEVE	BRASS	BRASS PER ASTM B16, ALLOY C36000, 1/2 HARD
INSULATION*	PTFE	PTFE PER ASTM D1710
NUT	BRASS	BRASS PER ASTM B16, ALLOY C36000, 1/2 HARD
WASHER	PHOSPHOR BRONZE	PHOSPHOR BRONZE PER MS35333

*For Insulation color, please see INSULATION COLOR OPTIONS on Page 2

FINISH - PLATING OPTIONS:

1125-45M-XXXXZ

FINISH CODE	COMPONENT	FINISH	FINISH AND SPECIFICATION
05	TERMINAL	ELECTRO-SOLDER	0.000300"MIN. ELECTRO-SOLDER PER SAE-AMS-P-81728 OVER 0.000100"MIN. COPPER PER SAE-AMS-2418
	BASE/METAL SLEEVE	ELECTRO-SOLDER	0.000100"MIN. ELECTRO-SOLDER PER SAE-AMS-P-81728 OVER 0.000100"MIN. NICKEL PER SAE-AMS-QQ-N-290
	NUT	NICKEL	0.000100"MIN. NICKEL PER SAE-AMS-QQ-N-290
	WASHER	NICKEL	0.000100"MIN. NICKEL PER SAE-AMS-QQ-N-290
088	TERMINAL	BRIGHT TIN-LEAD	0.000300"MIN. BRIGHT TIN-LEAD (Sn93%-Pb7%) PER ASTM B545 OVER 0.000100"MIN. COPPER PER SAE-AMS-2418
	BASE/METAL SLEEVE	BRIGHT TIN-LEAD	0.000100"MIN. BRIGHT TIN-LEAD (Sn93%-Pb7%) PER ASTM B545 OVER 0.000100"MIN. NICKEL PER SAE-AMS-QQ-N-290
	NUT	NICKEL	0.000100"MIN. NICKEL PER SAE-AMS-QQ-N-290
	WASHER	NICKEL	0.000100"MIN. NICKEL PER SAE-AMS-QQ-N-290
095	TERMINAL	HOT SOLDER DIP	0.000100"MIN. HOT SOLDER DIP USING Sn60 PER IPC-J-STD-006 OVER 0.000100"MIN. COPPER PER SAE-AMS-2418
	BASE/METAL SLEEVE	BRIGHT TIN-LEAD	0.000100"MIN. BRIGHT TIN-LEAD (Sn93%-Pb7%) PER ASTM B545 OVER 0.000100"MIN. NICKEL PER SAE-AMS-QQ-N-290
	NUT	NICKEL	0.000100"MIN. NICKEL PER SAE-AMS-QQ-N-290
	WASHER	NICKEL	0.000100"MIN. NICKEL PER SAE-AMS-QQ-N-290

INSULATION COLOR OPTIONS:

1125-45M-XXXXZ

INSULATION COLOR	BLACK	BLUE	BROWN	GRAY	GREEN	ORANGE	RED	VIOLET	WHITE	YELLOW
COLOR CODE NO.	10	16	11	18	15	13	12	17	19	14

TOLERANCES:*

DECIMAL	FRACTIONAL	ANGULAR	DRAWING ORIGATION DATE	LAST MODIFICATION DATE
± 0.015	N/A	N/A	7/15/1998	3/1/2017

*All dimensions are in inches.

RoHS COMPLIANCE:

1125-45M-05XXZ

PART NUMBER	RoHS COMPLIANT
1125-45M-0510Z	NO
1125-45M-0511Z	NO
1125-45M-0512Z	NO
1125-45M-0513Z	NO
1125-45M-0514Z	NO
1125-45M-0515Z	NO
1125-45M-0516Z	NO
1125-45M-0517Z	NO
1125-45M-0518Z	NO
1125-45M-0519Z	NO

1125-45M-088XXZ

PART NUMBER	RoHS COMPLIANT
1125-45M-08810Z	NO
1125-45M-08811Z	NO
1125-45M-08812Z	NO
1125-45M-08813Z	NO
1125-45M-08814Z	NO
1125-45M-08815Z	NO
1125-45M-08816Z	NO
1125-45M-08817Z	NO
1125-45M-08818Z	NO
1125-45M-08819Z	NO

1125-45M-095XXZ

PART NUMBER	RoHS COMPLIANT
1125-45M-09510Z	NO
1125-45M-09511Z	NO
1125-45M-09512Z	NO
1125-45M-09513Z	NO
1125-45M-09514Z	NO
1125-45M-09515Z	NO
1125-45M-09516Z	NO
1125-45M-09517Z	NO
1125-45M-09518Z	NO
1125-45M-09519Z	NO

MILITARY REFERENCE SPECIFICATIONS:

1125-45M-05XXZ

PART NUMBER	MIL SPECIFICATION	MIL PART NUMBER	COMMERCIAL ITEM DESCRIPTION (CID) SPECIFICATION	CID PART NUMBER
1125-45M-0510Z	MIL-T-55155/09	M55155/090B02 (SE090E02Z)	A-A-59126/09	AA59126/090B02
1125-45M-0511Z	MIL-T-55155/09	M55155/091B02 (SE091E02Z)	A-A-59126/09	AA59126/091B02
1125-45M-0512Z	MIL-T-55155/09	M55155/092B02 (SE092E02Z)	A-A-59126/09	AA59126/092B02
1125-45M-0513Z	MIL-T-55155/09	M55155/093B02 (SE093E02Z)	A-A-59126/09	AA59126/093B02
1125-45M-0514Z	MIL-T-55155/09	M55155/094B02 (SE094E02Z)	A-A-59126/09	AA59126/094B02
1125-45M-0515Z	MIL-T-55155/09	M55155/095B02 (SE095E02Z)	A-A-59126/09	AA59126/095B02
1125-45M-0516Z	MIL-T-55155/09	M55155/096B02 (SE096E02Z)	A-A-59126/09	AA59126/096B02
1125-45M-0517Z	MIL-T-55155/09	M55155/097B02 (SE097E02Z)	A-A-59126/09	AA59126/097B02
1125-45M-0518Z	MIL-T-55155/09	M55155/098B02 (SE098E02Z)	A-A-59126/09	AA59126/098B02
1125-45M-0519Z	MIL-T-55155/09	M55155/099B02 (SE099E02Z)	A-A-59126/09	AA59126/099B02

1125-45M-088XXZ

PART NUMBER	MIL SPECIFICATION	MIL PART NUMBER	COMMERCIAL ITEM DESCRIPTION (CID) SPECIFICATION	CID PART NUMBER
1125-45M-08810Z	MIL-T-55155/09	M55155/090D02	A-A-59126/09	AA59126/090D02
1125-45M-08811Z	MIL-T-55155/09	M55155/091D02	A-A-59126/09	AA59126/091D02
1125-45M-08812Z	MIL-T-55155/09	M55155/092D02	A-A-59126/09	AA59126/092D02
1125-45M-08813Z	MIL-T-55155/09	M55155/093D02	A-A-59126/09	AA59126/093D02
1125-45M-08814Z	MIL-T-55155/09	M55155/094D02	A-A-59126/09	AA59126/094D02

Continued on next page...

MILITARY REFERENCE SPECIFICATIONS CONTINUED:

1125-45M-088XXZ

PART NUMBER	MIL SPECIFICATION	MIL PART NUMBER	COMMERCIAL ITEM DESCRIPTION (CID) SPECIFICATION	CID PART NUMBER
1125-45M-08815Z	MIL-T-55155/09	M55155/095D02	A-A-59126/09	AA59126/095D02
1125-45M-08816Z	MIL-T-55155/09	M55155/096D02	A-A-59126/09	AA59126/096D02
1125-45M-08817Z	MIL-T-55155/09	M55155/097D02	A-A-59126/09	AA59126/097D02
1125-45M-08818Z	MIL-T-55155/09	M55155/098D02	A-A-59126/09	AA59126/098D02
1125-45M-08819Z	MIL-T-55155/09	M55155/099D02	A-A-59126/09	AA59126/099D02

1125-45M-095XXZ

PART NUMBER	MIL SPECIFICATION	MIL PART NUMBER	COMMERCIAL ITEM DESCRIPTION (CID) SPECIFICATION	CID PART NUMBER
1125-45M-09510Z	MIL-T-55155/09	M55155/090C02	A-A-59126/09	AA59126/090C02
1125-45M-09511Z	MIL-T-55155/09	M55155/091C02	A-A-59126/09	AA59126/091C02
1125-45M-09512Z	MIL-T-55155/09	M55155/092C02	A-A-59126/09	AA59126/092C02
1125-45M-09513Z	MIL-T-55155/09	M55155/093C02	A-A-59126/09	AA59126/093C02
1125-45M-09514Z	MIL-T-55155/09	M55155/094C02	A-A-59126/09	AA59126/094C02
1125-45M-09515Z	MIL-T-55155/09	M55155/095C02	A-A-59126/09	AA59126/095C02
1125-45M-09516Z	MIL-T-55155/09	M55155/096C02	A-A-59126/09	AA59126/096C02
1125-45M-09517Z	MIL-T-55155/09	M55155/097C02	A-A-59126/09	AA59126/097C02
1125-45M-09518Z	MIL-T-55155/09	M55155/098C02	A-A-59126/09	AA59126/098C02
1125-45M-09519Z	MIL-T-55155/09	M55155/099C02	A-A-59126/09	AA59126/099C02

TOOLING:

INSTALLATION TOOL: ARBOR PRESS	INSTALLATION TOOL: ANVIL (ARBOR PRESS OPERATED)	INSTALLATION TOOL: PRESS-FIT / ROLL SWAGE / RIVET PUNCH (ARBOR PRESS OPERATED)	INSTALLATION TOOL: PRESS-FIT (HAND OPERATED)
N/A	N/A	N/A	N/A

NOTES:

DATASHEET NOTES

NUT PART NO.: 701-7320-02, WASHER PART NO.: 701-7722-02.

INSTRUCTION NOTES

SUPPLIED WITH NICKEL PLATED BRASS HEX NUT (6-32 x 5/16" x 7/64") AND NICKEL PLATED PHOSPHOR BRONZE #6 INTERNAL TOOTH LOCKWASHER.