

DRAWING NUMBER:	15R-601-X-XX
PRODUCT GROUP:	TERMINALS
SUB-GROUP:	MILITARY NON-INSULATED TERMINALS
DESCRIPTION:	NON-INSULATED TRIPLE TURRET TERMINAL

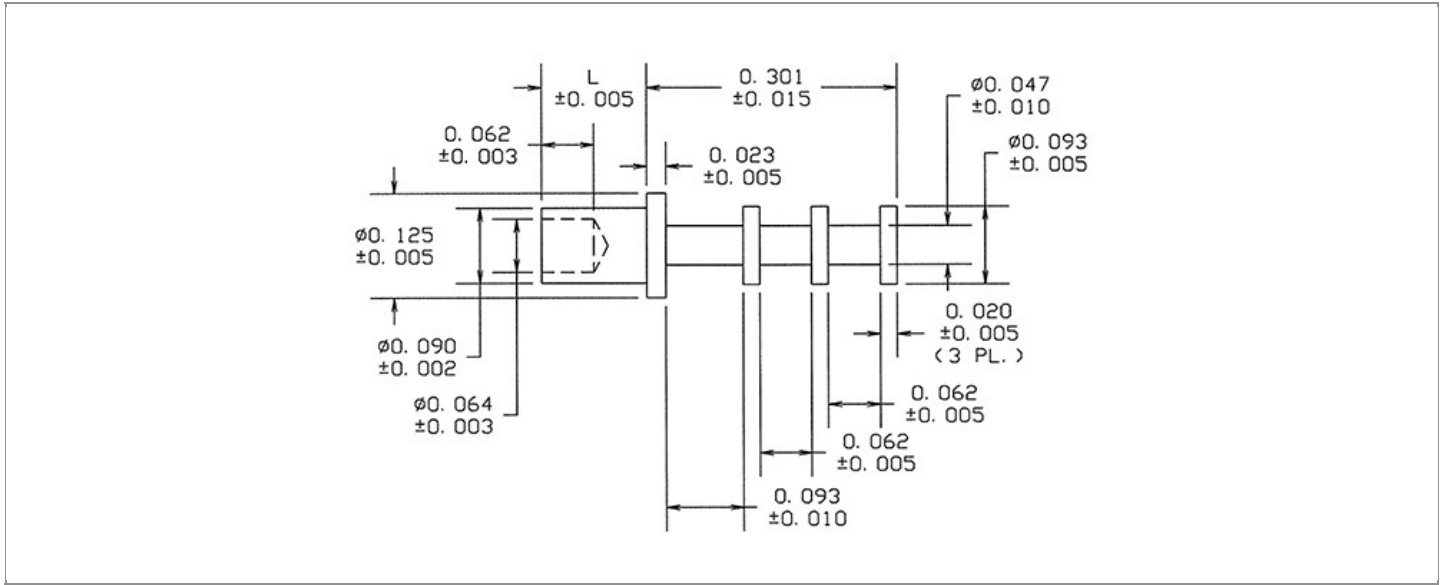

BOARD / PANEL MOUNTING METHOD	MOUNTING HOLE SIZE	DRILL SIZE	FEED THRU COMBINATION
SWAGE MOUNT	0.094" \pm 0.001	3/32"	N/A

PART NO. STRUCTURE:

15R-601 - **X** - **XX**
 PART SERIES DIMENSION FINISH

MATERIAL OPTIONS:

15R-601-X-XX

COMPONENT	MATERIAL	MATERIAL AND SPECIFICATION
TERMINAL	PHOSPHOR BRONZE	PHOSPHOR BRONZE PER ASTM B139, ALLOY C54400

DIMENSION OPTIONS:

15R-601-X-XX

DIMENSION	K	OVERALL LENGTH	SHANK LENGTH (L)	BOARD/PANEL THICKNESS
1	N/A	0.363"	0.062"	1/32"
2	N/A	0.394"	0.093"	1/16"
3	N/A	0.426"	0.125"	3/32"
4	N/A	0.457"	0.156"	1/8"
6	N/A	0.519"	0.218"	3/16"

FINISH - PLATING OPTIONS:

15R-601-X-**XX**

FINISH CODE	COMPONENT	FINISH	FINISH AND SPECIFICATION
05	TERMINAL	ELECTRO-SOLDER	0.000300"MIN. ELECTRO-SOLDER PER SAE-AMS-P-81728 OVER 0.000100"MIN. COPPER PER SAE-AMS-2418
088	TERMINAL	BRIGHT TIN-LEAD	0.000300"MIN. BRIGHT TIN-LEAD (Sn93%-Pb7%) PER ASTM B545 OVER 0.000100"MIN. COPPER PER SAE-AMS-2418
095	TERMINAL	HOT SOLDER DIP	0.000100"MIN. HOT SOLDER DIP USING Sn60 PER IPC-J-STD-006 OVER 0.000100"MIN. COPPER PER SAE-AMS-2418

TOLERANCES:*

DECIMAL	FRACTIONAL	ANGULAR	DRAWING ORIGATION DATE	LAST MODIFICATION DATE
N/A	N/A	N/A	11/4/2002	3/1/2017

*All dimensions are in inches.

RoHS COMPLIANCE:

15R-601-1-XX

PART NUMBER	RoHS COMPLIANT
15R-601-1-05	NO
15R-601-1-088	NO
15R-601-1-095	NO

15R-601-2-XX

PART NUMBER	RoHS COMPLIANT
15R-601-2-05	NO
15R-601-2-088	NO
15R-601-2-095	NO

15R-601-3-XX

PART NUMBER	RoHS COMPLIANT
15R-601-3-05	NO
15R-601-3-088	NO
15R-601-3-095	NO

15R-601-4-XX

PART NUMBER	RoHS COMPLIANT
15R-601-4-05	NO
15R-601-4-088	NO
15R-601-4-095	NO

15R-601-6-XX

PART NUMBER	RoHS COMPLIANT
15R-601-6-05	NO
15R-601-6-088	NO
15R-601-6-095	NO

MILITARY REFERENCE SPECIFICATIONS:

15R-601-1-XX

PART NUMBER	MIL SPECIFICATION	MIL PART NUMBER	COMMERCIAL ITEM DESCRIPTION (CID) SPECIFICATION	CID PART NUMBER
15R-601-1-05	MIL-T-55155/31	M55155/31XB01 (M55155/31-1Z; SE31XC01Z)	A-A-59126/31	AA59126/31XB01
15R-601-1-088	MIL-T-55155/31	M55155/31XD01	A-A-59126/31	AA59126/31XD01
15R-601-1-095	MIL-T-55155/31	M55155/31XC01	A-A-59126/31	AA59126/31XC01

Continued on next page...

MILITARY REFERENCE SPECIFICATIONS CONTINUED:

15R-601-2-XX

PART NUMBER	MIL SPECIFICATION	MIL PART NUMBER	COMMERCIAL ITEM DESCRIPTION (CID) SPECIFICATION	CID PART NUMBER
15R-601-2-05	MIL-T-55155/31	M55155/31XB03 (M55155/31-3Z; SE31XC03Z)	A-A-59126/31	AA59126/31XB03
15R-601-2-088	MIL-T-55155/31	M55155/31XD03	A-A-59126/31	AA59126/31XD03
15R-601-2-095	MIL-T-55155/31	M55155/31XC03	A-A-59126/31	AA59126/31XC03

15R-601-3-XX

PART NUMBER	MIL SPECIFICATION	MIL PART NUMBER	COMMERCIAL ITEM DESCRIPTION (CID) SPECIFICATION	CID PART NUMBER
15R-601-3-05	MIL-T-55155/31	M55155/31XB05 (M55155/31-5Z; SE31XC05Z)	A-A-59126/31	AA59126/31XB05
15R-601-3-088	MIL-T-55155/31	M55155/31XD05	A-A-59126/31	AA59126/31XD05
15R-601-3-095	MIL-T-55155/31	M55155/31XC05	A-A-59126/31	AA59126/31XC05

15R-601-4-XX

PART NUMBER	MIL SPECIFICATION	MIL PART NUMBER	COMMERCIAL ITEM DESCRIPTION (CID) SPECIFICATION	CID PART NUMBER
15R-601-4-05	MIL-T-55155/31	M55155/31XB07 (M55155/31-7Z; SE31XC07Z)	A-A-59126/31	AA59126/31XB07
15R-601-4-088	MIL-T-55155/31	M55155/31XD07	A-A-59126/31	AA59126/31XD07
15R-601-4-095	MIL-T-55155/31	M55155/31XC07	A-A-59126/31	AA59126/31XC07

15R-601-6-XX

PART NUMBER	MIL SPECIFICATION	MIL PART NUMBER	COMMERCIAL ITEM DESCRIPTION (CID) SPECIFICATION	CID PART NUMBER
15R-601-6-05	MIL-T-55155/31	M55155/31XB10 (M55155/31-10Z; SE31XC10Z)	A-A-59126/31	AA59126/31XB10
15R-601-6-088	MIL-T-55155/31	M55155/31XD10	A-A-59126/31	AA59126/31XD10
15R-601-6-095	MIL-T-55155/31	M55155/31XC10	A-A-59126/31	AA59126/31XC10

TOOLING:

INSTALLATION TOOL: ARBOR PRESS	INSTALLATION TOOL: ANVIL (ARBOR PRESS OPERATED)	INSTALLATION TOOL: PRESS-FIT / ROLL SWAGE / RIVET PUNCH (ARBOR PRESS OPERATED)	INSTALLATION TOOL: FLARE SWAGE PUNCH (ARBOR PRESS OPERATED)
TM1	TA125-94-23	TP90-64	TFLP90-175

NOTES:

DATASHEET NOTES

N/A

INSTRUCTION NOTES

SEE GENERAL SWAGING INSTALLATION INSTRUCTION ON CONCORD ELECTRONICS' WEBSITE WWW.CONCORD-ELECTRONICS.COM
