

<b>DRAWING NUMBER:</b>	<b>15-541-X-XX</b>
<b>PRODUCT GROUP:</b>	TERMINALS
<b>SUB-GROUP:</b>	MILITARY NON-INSULATED TERMINALS
<b>DESCRIPTION:</b>	NON-INSULATED FEED THRU (TURRET/DOUBLE TURRET) TERMINAL

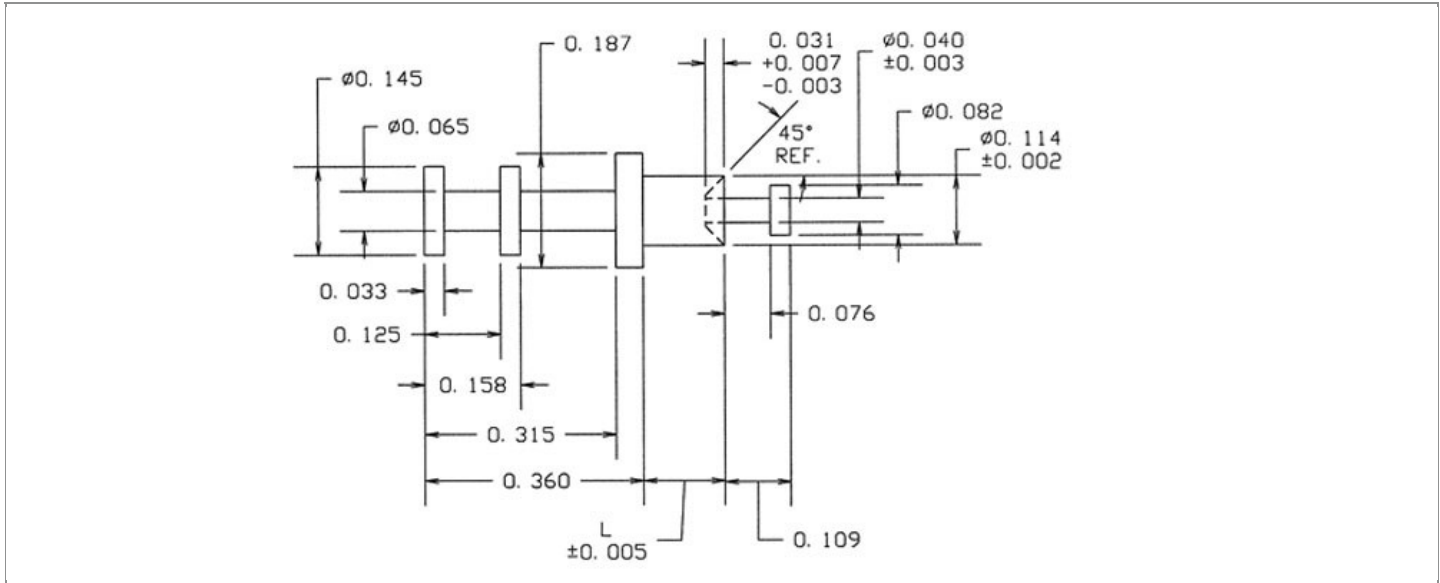

BOARD / PANEL MOUNTING METHOD	MOUNTING HOLE SIZE	DRILL SIZE	FEED THRU COMBINATION
SWAGE MOUNT	0.116" ± 0.001	#32	TURRET/DOUBLE TURRET

**PART NO. STRUCTURE:**

15-541 - X - XX  
 PART SERIES    DIMENSION    FINISH

**MATERIAL OPTIONS:**

15-541-X-XX

COMPONENT	MATERIAL	MATERIAL AND SPECIFICATION
TERMINAL	BRASS	BRASS PER ASTM B16, ALLOY C36000, 1/2 HARD

**DIMENSION OPTIONS:**

15-541-X-XX

DIMENSION	K	OVERALL LENGTH	SHANK LENGTH (L)	BOARD/PANEL THICKNESS
2	N/A	0.574"	0.105"	1/16"
3	N/A	0.604"	0.135"	3/32"
4	N/A	0.634"	0.165"	1/8"

FINISH - PLATING OPTIONS:

15-541-X-XX

FINISH CODE	COMPONENT	FINISH	FINISH AND SPECIFICATION
05	TERMINAL	ELECTRO-SOLDER	0.000300"MIN. ELECTRO-SOLDER PER SAE-AMS-P-81728 OVER 0.000100"MIN. COPPER PER SAE-AMS-2418
088	TERMINAL	BRIGHT TIN-LEAD	0.000300"MIN. BRIGHT TIN-LEAD (Sn93%-Pb7%) PER ASTM B545 OVER 0.000100"MIN. COPPER PER SAE-AMS-2418
095	TERMINAL	HOT SOLDER DIP	0.000100"MIN. HOT SOLDER DIP USING Sn60 PER IPC-J-STD-006 OVER 0.000100"MIN. COPPER PER SAE-AMS-2418

TOLERANCES:\*

DECIMAL	FRACTIONAL	ANGULAR	DRAWING ORIGATION DATE	LAST MODIFICATION DATE
± 0.005	N/A	± 3 °	11/4/2002	3/1/2017

\*All dimensions are in inches.

RoHS COMPLIANCE:

15-541-2-XX

PART NUMBER	RoHS COMPLIANT
15-541-2-05	NO
15-541-2-088	NO
15-541-2-095	NO

15-541-3-XX

PART NUMBER	RoHS COMPLIANT
15-541-3-05	NO
15-541-3-088	NO
15-541-3-095	NO

15-541-4-XX

PART NUMBER	RoHS COMPLIANT
15-541-4-05	NO
15-541-4-088	NO
15-541-4-095	NO

MILITARY REFERENCE SPECIFICATIONS:

15-541-2-XX

PART NUMBER	MIL SPECIFICATION	MIL PART NUMBER	COMMERCIAL ITEM DESCRIPTION (CID) SPECIFICATION	CID PART NUMBER
15-541-2-05	MIL-T-55155/14	M55155/14XH04 (M55155/14-4S; SE14XC04S)	A-A-59126/14	AA59126/14XH04
15-541-2-088	MIL-T-55155/14	M55155/14XJ04	A-A-59126/14	AA59126/14XJ04 (AA59126/1404)
15-541-2-095	MIL-T-55155/14	M55155/14XI04	A-A-59126/14	AA59126/14XI04

15-541-3-XX

PART NUMBER	MIL SPECIFICATION	MIL PART NUMBER	COMMERCIAL ITEM DESCRIPTION (CID) SPECIFICATION	CID PART NUMBER
15-541-3-05	MIL-T-55155/14	M55155/14XH05 (M55155/14-5S; SE14XC05S)	A-A-59126/14	AA59126/14XH05
15-541-3-088	MIL-T-55155/14	M55155/14XJ05	A-A-59126/14	AA59126/14XJ05 (AA59126/1405)
15-541-3-095	MIL-T-55155/14	M55155/14XI05	A-A-59126/14	AA59126/14XI05

Continued on next page...

MILITARY REFERENCE SPECIFICATIONS CONTINUED:

15-541-4-XX

PART NUMBER	MIL SPECIFICATION	MIL PART NUMBER	COMMERCIAL ITEM DESCRIPTION (CID) SPECIFICATION	CID PART NUMBER
15-541-4-05	MIL-T-55155/14	M55155/14XH06 (M55155/14-6S; SE14XC06S)	A-A-59126/14	AA59126/14XH06
15-541-4-088	MIL-T-55155/14	M55155/14XJ06	A-A-59126/14	AA59126/14XJ06 (AA59126/1406)
15-541-4-095	MIL-T-55155/14	M55155/14XI06	A-A-59126/14	AA59126/14XI06

TOOLING:

INSTALLATION TOOL: ARBOR PRESS	INSTALLATION TOOL: ANVIL (ARBOR PRESS OPERATED)	INSTALLATION TOOL: PRESS-FIT / ROLL SWAGE / RIVET PUNCH (ARBOR PRESS OPERATED)	INSTALLATION TOOL: FLARE SWAGE PUNCH (ARBOR PRESS OPERATED)
TM1	TA188-146-31	TP114-T82	N/A

NOTES:

DATASHEET NOTES
N/A

INSTRUCTION NOTES
SEE GENERAL SWAGING INSTALLATION INSTRUCTION ON CONCORD ELECTRONICS' WEBSITE <a href="http://WWW.CONCORD-ELECTRONICS.COM">WWW.CONCORD-ELECTRONICS.COM</a>