

DRAWING NUMBER:	15-266-X-XX
PRODUCT GROUP:	TERMINALS
SUB-GROUP:	MILITARY NON-INSULATED TERMINALS
DESCRIPTION:	NON-INSULATED DOUBLE TURRET TERMINAL

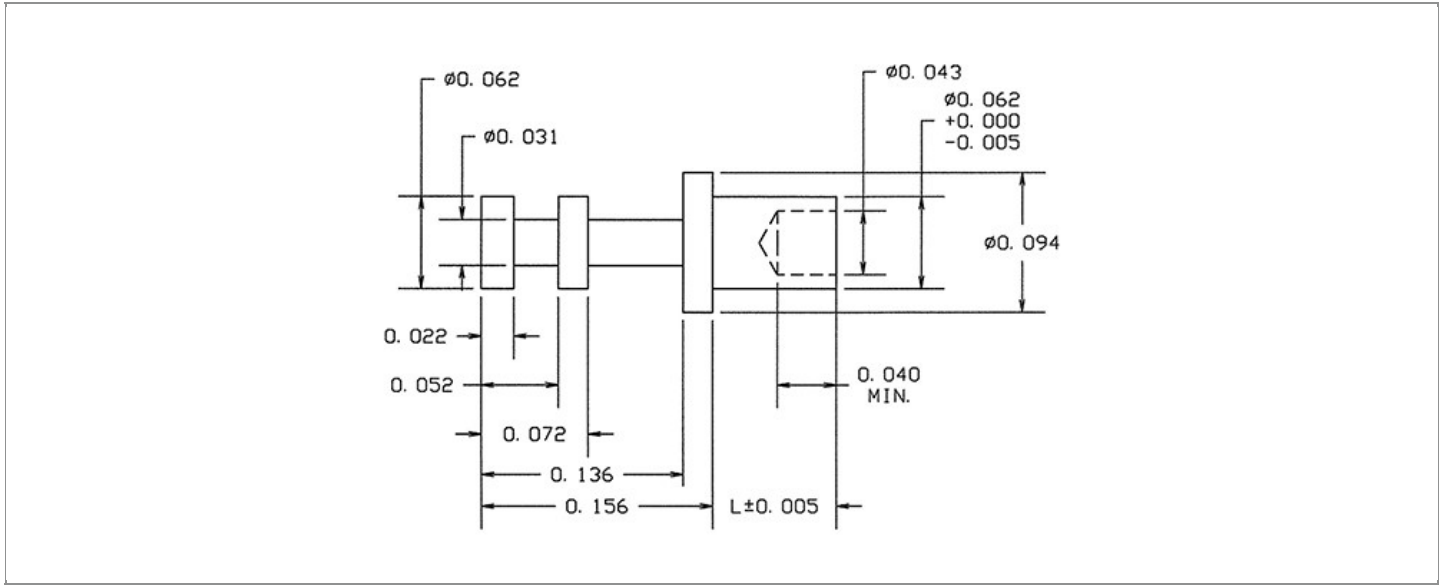

BOARD / PANEL MOUNTING METHOD	MOUNTING HOLE SIZE	DRILL SIZE	FEED THRU COMBINATION
SWAGE MOUNT	0.0635" ± 0.001	#52	N/A

PART NO. STRUCTURE:

15-266 - X - XX
 PART SERIES DIMENSION FINISH

MATERIAL OPTIONS:

15-266-X-XX

COMPONENT	MATERIAL	MATERIAL AND SPECIFICATION
TERMINAL	BRASS	BRASS PER ASTM B16, ALLOY C36000, 1/2 HARD

DIMENSION OPTIONS:

15-266-X-XX

DIMENSION	K	OVERALL LENGTH	SHANK LENGTH (L)	BOARD/PANEL THICKNESS
1	N/A	0.209"	0.053"	1/32"
2	N/A	0.240"	0.084"	1/16"
3	N/A	0.271"	0.115"	3/32"
4	N/A	0.303"	0.147"	1/8"

FINISH - PLATING OPTIONS:

15-266-X-XX

FINISH CODE	COMPONENT	FINISH	FINISH AND SPECIFICATION
05	TERMINAL	ELECTRO-SOLDER	0.000300"MIN. ELECTRO-SOLDER PER SAE-AMS-P-81728 OVER 0.000100"MIN. COPPER PER SAE-AMS-2418
088	TERMINAL	BRIGHT TIN-LEAD	0.000300"MIN. BRIGHT TIN-LEAD (Sn93%-Pb7%) PER ASTM B545 OVER 0.000100"MIN. COPPER PER SAE-AMS-2418
095	TERMINAL	HOT SOLDER DIP	0.000100"MIN. HOT SOLDER DIP USING Sn60 PER IPC-J-STD-006 OVER 0.000100"MIN. COPPER PER SAE-AMS-2418

TOLERANCES:*

DECIMAL	FRACTIONAL	ANGULAR	DRAWING ORIENTATION DATE	LAST MODIFICATION DATE
± 0.005	N/A	± 3 °	12/9/2004	3/1/2017

*All dimensions are in inches.

RoHS COMPLIANCE:

15-266-1-XX

PART NUMBER	RoHS COMPLIANT
15-266-1-05	NO
15-266-1-088	NO
15-266-1-095	NO

15-266-2-XX

PART NUMBER	RoHS COMPLIANT
15-266-2-05	NO
15-266-2-088	NO
15-266-2-095	NO

15-266-3-XX

PART NUMBER	RoHS COMPLIANT
15-266-3-05	NO
15-266-3-088	NO
15-266-3-095	NO

15-266-4-XX

PART NUMBER	RoHS COMPLIANT
15-266-4-05	NO
15-266-4-088	NO
15-266-4-095	NO

MILITARY REFERENCE SPECIFICATIONS:

15-266-1-XX

PART NUMBER	MIL SPECIFICATION	MIL PART NUMBER	COMMERCIAL ITEM DESCRIPTION (CID) SPECIFICATION	CID PART NUMBER
15-266-1-05	MIL-T-55155/12	M55155/12XH10 (M55155/12-10S; SE12XC10S)	A-A-59126/12	AA59126/12XH10
15-266-1-088	MIL-T-55155/12	M55155/12XJ10	A-A-59126/12	AA59126/12XJ10 (AA59126/1210)
15-266-1-095	MIL-T-55155/12	M55155/12XI10	A-A-59126/12	AA59126/12XI10

Continued on next page...

MILITARY REFERENCE SPECIFICATIONS CONTINUED:

15-266-2-XX

PART NUMBER	MIL SPECIFICATION	MIL PART NUMBER	COMMERCIAL ITEM DESCRIPTION (CID) SPECIFICATION	CID PART NUMBER
15-266-2-05	MIL-T-55155/12	M55155/12XH11 (M55155/12-11S; SE12XC11S)	A-A-59126/12	AA59126/12XH11
15-266-2-088	MIL-T-55155/12	M55155/12XJ11	A-A-59126/12	AA59126/12XJ11 (AA59126/1211)
15-266-2-095	MIL-T-55155/12	M55155/12XI11	A-A-59126/12	AA59126/12XI11

15-266-3-XX

PART NUMBER	MIL SPECIFICATION	MIL PART NUMBER	COMMERCIAL ITEM DESCRIPTION (CID) SPECIFICATION	CID PART NUMBER
15-266-3-05	MIL-T-55155/12	M55155/12XH12 (M55155/12-12S; SE12XC12S)	A-A-59126/12	AA59126/12XH12
15-266-3-088	MIL-T-55155/12	M55155/12XJ12	A-A-59126/12	AA59126/12XJ12 (AA59126/1212)
15-266-3-095	MIL-T-55155/12	M55155/12XI12	A-A-59126/12	AA59126/12XI12

15-266-4-XX

PART NUMBER	MIL SPECIFICATION	MIL PART NUMBER	COMMERCIAL ITEM DESCRIPTION (CID) SPECIFICATION	CID PART NUMBER
15-266-4-05	MIL-T-55155/12	M55155/12XH13 (M55155/12-13S; SE12XC13S)	A-A-59126/12	AA59126/12XH13
15-266-4-088	MIL-T-55155/12	M55155/12XJ13	A-A-59126/12	AA59126/12XJ13 (AA59126/1213)
15-266-4-095	MIL-T-55155/12	M55155/12XI13	A-A-59126/12	AA59126/12XI13

TOOLING:

INSTALLATION TOOL: ARBOR PRESS	INSTALLATION TOOL: ANVIL (ARBOR PRESS OPERATED)	INSTALLATION TOOL: PRESS-FIT / ROLL SWAGE / RIVET PUNCH (ARBOR PRESS OPERATED)	INSTALLATION TOOL: FLARE SWAGE PUNCH (ARBOR PRESS OPERATED)
TM1	TA94-62-20	TP62-44	TFLP90-150

NOTES:

DATASHEET NOTES
N/A
INSTRUCTION NOTES
SEE GENERAL SWAGING INSTALLATION INSTRUCTION ON CONCORD ELECTRONICS' WEBSITE WWW.CONCORD-ELECTRONICS.COM