

| | |
|------------------------|--|
| DRAWING NUMBER: | 09-9228-1-XXXX |
| PRODUCT GROUP: | PANEL JACKS AND TERMINALS |
| SUB-GROUP: | PANEL JACKS AND TERMINALS - THREAD MOUNT |
| DESCRIPTION: | PANEL JACK - METAL THREAD |

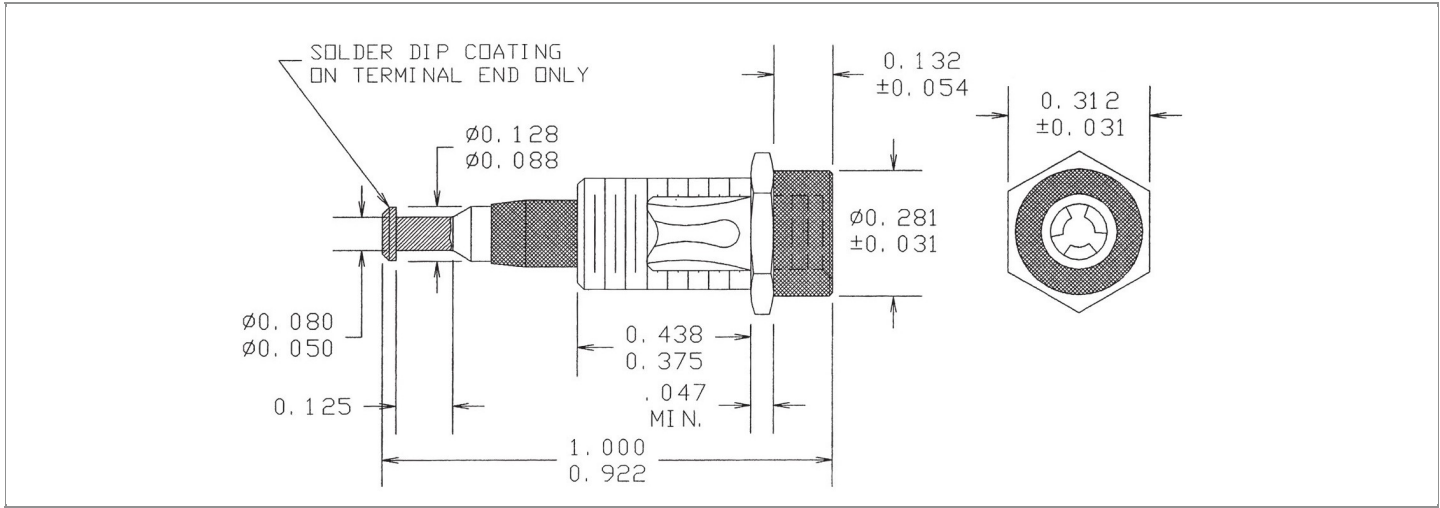

| ACCEPTS PIN / PLUG / JACK SIZE | MIN. HOLE DEPTH | MOUNTING ORIENTATION | BOARD / PANEL MOUNTING METHOD |
|--------------------------------|-------------------------|-----------------------|-------------------------------|
| 0.080" ± 0.001 | 0.420" | VERTICAL | THREAD MOUNT (1/4-32 NUT) |
| MOUNTING HOLE SIZE | BOARD / PANEL THICKNESS | FEED THRU COMBINATION | OVERALL LENGTH |
| 0.257" ± 0.002 | UP TO 3/16" | JACK/TURRET | 0.922" |

PART NO. STRUCTURE:

| | | | | | |
|----------------|---|-----------|---|-----------|------------------|
| 09-9228 | - | 1 | - | XX | XX |
| PART SERIES | | DIMENSION | | FINISH | INSULATION COLOR |

MATERIAL OPTIONS:

09-9228-1-XXXX

| COMPONENT | MATERIAL | MATERIAL AND SPECIFICATION |
|-------------------|------------------|--|
| BODY | BRASS | BRASS PER ASTM B16, ALLOY C36000, 1/2 HARD |
| SPRING (CAGE) | BERYLLIUM COPPER | BERYLLIUM COPPER PER ASTM B194, ALLOY C17200 |
| INSULATION* | NYLON | NYLON PER ASTM D4066 |
| BASE/METAL SLEEVE | BRASS | BRASS PER ASTM B16, ALLOY C36000, 1/2 HARD |
| NUT | BRASS | BRASS PER ASTM B16, ALLOY C36000, 1/2 HARD |
| WASHER | PHOSPHOR BRONZE | PHOSPHOR BRONZE PER ASTM B139/B103, ALLOY C51000 |
| LUG | N/A | N/A |

*For Insulation color, please see INSULATION COLOR OPTIONS on Page 2

FINISH - PLATING OPTIONS:

09-9228-1-XXXX

| FINISH CODE | COMPONENT | FINISH | FINISH AND SPECIFICATION |
|-------------|-------------------|-----------------------------|--|
| 03 | BODY | GOLD WITH SOLDER COATED TIP | 0.000010"MIN. GOLD PER ASTM B488, TYPE II, CODE C OVER 0.000100"MIN. NICKEL PER SAE-AMS-QQ-N-290, CLASS 2. TIP WITH SOLDER COATING |
| | SPRING (CAGE) | GOLD | 0.000030"MIN. GOLD PER ASTM B488, TYPE II, CODE C OVER 0.000100"MIN. NICKEL PER SAE-AMS-QQ-N-290, CLASS 2 |
| | BASE/METAL SLEEVE | NICKEL | 0.000100"MIN. NICKEL PER SAE-AMS-QQ-N-290, CLASS 2 |
| | NUT | NICKEL | 0.000100"MIN. NICKEL PER SAE-AMS-QQ-N-290, CLASS 2 |
| | WASHER | NICKEL | 0.000100"MIN. NICKEL PER SAE-AMS-QQ-N-290, CLASS 2 |
| | LUG | N/A | N/A |
| 035 | BODY | GOLD WITH SOLDER COATED TIP | 0.000020"MIN. GOLD PER ASTM B488, TYPE II, CODE C OVER 0.000030"-0.000150" NICKEL PER SAE-AMS-QQ-N-290, CLASS 2. TIP WITH SOLDER COATING |
| | SPRING (CAGE) | GOLD | 0.000050"MIN. GOLD PER ASTM B488, TYPE II, CODE C OVER 0.000030"-0.000150" NICKEL PER SAE-AMS-QQ-N-290, CLASS 2 |
| | BASE/METAL SLEEVE | NICKEL | 0.000200"MIN. NICKEL PER SAE-AMS-QQ-N-290, CLASS 1 |
| | NUT | NICKEL | 0.000200"MIN. NICKEL PER SAE-AMS-QQ-N-290, CLASS 1 |
| | WASHER | NICKEL | 0.000200"MIN. NICKEL PER SAE-AMS-QQ-N-290, CLASS 1 |
| | LUG | N/A | N/A |

INSULATION COLOR OPTIONS:

09-9228-1-XXXX

| INSULATION COLOR | BLACK | BLUE | BROWN | GRAY | GREEN | ORANGE | RED | VIOLET | WHITE | YELLOW |
|------------------|-------|------|-------|------|-------|--------|-----|--------|-------|--------|
| COLOR CODE NO. | 10 | 16 | 11 | 18 | 15 | 13 | 12 | 17 | 19 | 14 |

TOLERANCES:*

| DECIMAL | FRACTIONAL | ANGULAR | DRAWING ORIGINATION DATE | LAST MODIFICATION DATE |
|---------|------------|---------|--------------------------|------------------------|
| ± 0.010 | ± 1/64 | ± 5 ° | 12/26/1997 | 1/1/2017 |

*All dimensions are in inches.

RoHS COMPLIANCE:

09-9228-1-03XX

| PART NUMBER | RoHS COMPLIANT |
|----------------|----------------|
| 09-9228-1-0310 | NO |
| 09-9228-1-0311 | NO |
| 09-9228-1-0312 | NO |
| 09-9228-1-0313 | NO |
| 09-9228-1-0314 | NO |
| 09-9228-1-0315 | NO |
| 09-9228-1-0316 | NO |
| 09-9228-1-0317 | NO |
| 09-9228-1-0318 | NO |
| 09-9228-1-0319 | NO |

09-9228-1-035XX

| PART NUMBER | RoHS COMPLIANT |
|-----------------|----------------|
| 09-9228-1-03510 | NO |
| 09-9228-1-03511 | NO |
| 09-9228-1-03512 | NO |
| 09-9228-1-03513 | NO |
| 09-9228-1-03514 | NO |
| 09-9228-1-03515 | NO |
| 09-9228-1-03516 | NO |
| 09-9228-1-03517 | NO |
| 09-9228-1-03518 | NO |
| 09-9228-1-03519 | NO |

MILITARY REFERENCE SPECIFICATIONS:

09-9228-1-03XX

| PART NUMBER | MIL SPECIFICATION | MIL PART NUMBER |
|----------------|-------------------|-----------------|
| 09-9228-1-0310 | N/A | N/A |
| 09-9228-1-0311 | N/A | N/A |
| 09-9228-1-0312 | N/A | N/A |
| 09-9228-1-0313 | N/A | N/A |
| 09-9228-1-0314 | N/A | N/A |
| 09-9228-1-0315 | N/A | N/A |
| 09-9228-1-0316 | N/A | N/A |
| 09-9228-1-0317 | N/A | N/A |
| 09-9228-1-0318 | N/A | N/A |
| 09-9228-1-0319 | N/A | N/A |

09-9228-1-035XX

| PART NUMBER | MIL SPECIFICATION | MIL PART NUMBER |
|-----------------|-------------------|-----------------|
| 09-9228-1-03510 | MIL-DTL-39024/10 | M39024/10-03 |
| 09-9228-1-03511 | MIL-DTL-39024/10 | M39024/10-04 |
| 09-9228-1-03512 | MIL-DTL-39024/10 | M39024/10-02 |
| 09-9228-1-03513 | MIL-DTL-39024/10 | M39024/10-06 |
| 09-9228-1-03514 | MIL-DTL-39024/10 | M39024/10-08 |
| 09-9228-1-03515 | MIL-DTL-39024/10 | M39024/10-05 |
| 09-9228-1-03516 | MIL-DTL-39024/10 | M39024/10-07 |
| 09-9228-1-03517 | MIL-DTL-39024/10 | M39024/10-10 |
| 09-9228-1-03518 | MIL-DTL-39024/10 | M39024/10-09 |
| 09-9228-1-03519 | MIL-DTL-39024/10 | M39024/10-01 |

NOTES:

DATASHEET NOTES

FOR PART NO. WITH FINISH "03": SOLDER DIP COATING ON TERMINAL END ONLY, NUT PART NO.: 701-7414-02, WASHER PART NO.: 701-7705-02; FOR PART NO. WITH FINISH "035": SOLDER DIP COATING ON TERMINAL END ONLY, NUT PART NO.: 701-7414-022, WASHER PART NO.: 701-7705-022.

INSTRUCTION NOTES

SUPPLIED WITH NICKEL PLATED BRASS HEX NUT (1/4-32 x 11/32" x 3/32") AND NICKEL PLATED PHOSPHOR BRONZE 1/4 INTERNAL TOOTH LOCKWASHER.