

DRAWING NUMBER:	09-9245-X-XX
PRODUCT GROUP:	PC JACKS
SUB-GROUP:	NON-INSULATED PC JACKS
DESCRIPTION:	PC JACK - NON-INSULATED

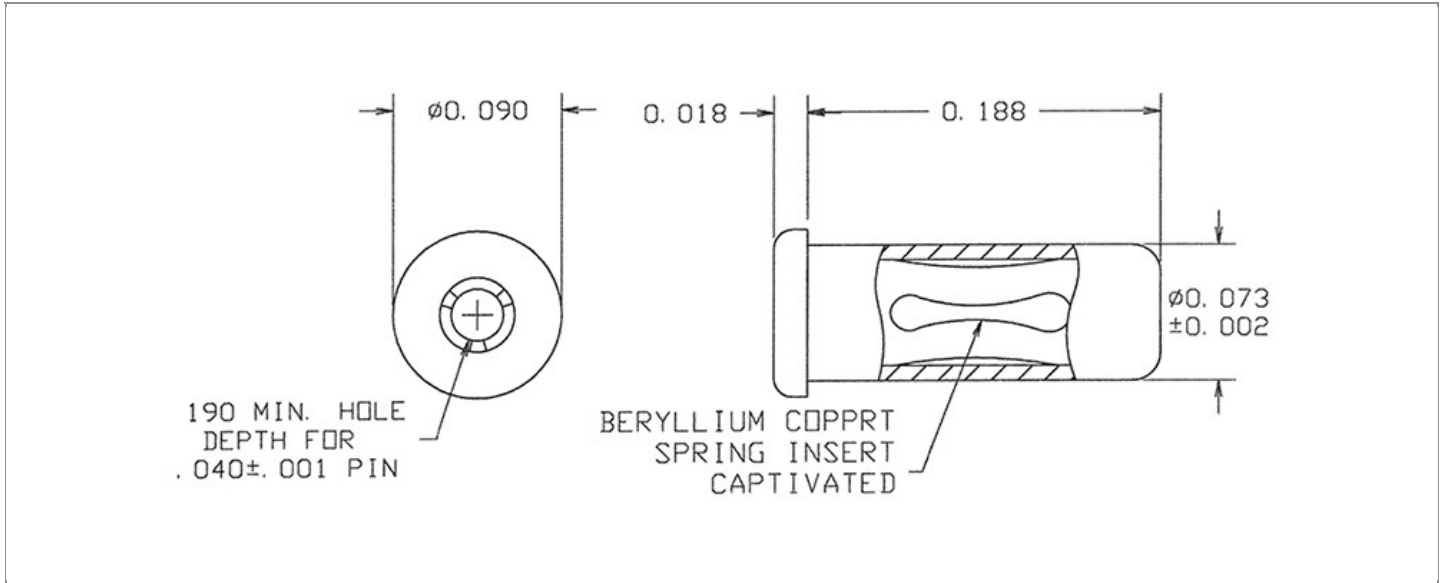

ACCEPTS PIN / PLUG / JACK SIZE	MOUNTING ORIENTATION	BOARD / PANEL MOUNTING METHOD	MOUNTING HOLE SIZE	DRILL SIZE	FEED THRU COMBINATION
0.040" \pm 0.001	VERTICAL	SOLDER	0.076" (+0.002/-0.001)	#48	N/A

PART NO. STRUCTURE:

09-9245 - **1** - **XX**
 PART SERIES DIMENSION FINISH

MATERIAL OPTIONS:

09-9245-1-XX

COMPONENT	MATERIAL	MATERIAL AND SPECIFICATION
BODY	LEADED RED BRASS	LEADED RED BRASS PER ASTM B140, ALLOY C31400, 1/2 HARD
SPRING (CAGE)	BERYLLIUM COPPER	BERYLLIUM COPPER PER ASTM B194, ALLOY C17200
MOUNTING BRACKET	N/A	N/A

DIMENSION OPTIONS:

09-9245-1-XX

DIMENSION	A	H	OVERALL LENGTH	MIN. HOLE DEPTH	SHANK LENGTH (L)	BOARD/PANEL THICKNESS
1	N/A	N/A	0.206"	0.190"	N/A	1/32" - 5/32"

FINISH - PLATING OPTIONS:

09-9245-1-XX

FINISH CODE	COMPONENT	FINISH	FINISH AND SPECIFICATION
99	BODY	GOLD	0.000010"MIN. GOLD PER ASTM B488, TYPE II, CODE C OVER 0.000100"MIN. COPPER PER SAE-AMS-2418
	SPRING (CAGE)	GOLD	0.000030"MIN. GOLD PER ASTM B488, TYPE II, CODE C OVER 0.000100"MIN. COPPER PER SAE-AMS-2418
	MOUNTING BRACKET	N/A	N/A

TOLERANCES:*

DECIMAL	FRACTIONAL	ANGULAR	DRAWING ORIGATION DATE	LAST MODIFICATION DATE
± 0.005	± 1/64	N/A	11/30/01	01/01/17

*All dimensions are in inches.

RoHS COMPLIANCE:

09-9245-1-XX

PART NUMBER	RoHS COMPLIANT
09-9245-1-99	YES

TOOLING:

INSTALLATION TOOL: ARBOR PRESS	INSTALLATION TOOL: ANVIL (ARBOR PRESS OPERATED)	INSTALLATION TOOL: PRESS-FIT / ROLL SWAGE / RIVET PUNCH (ARBOR PRESS OPERATED)	CRIMPING TOOL (COMMERCIAL VERSION)
N/A	N/A	N/A	N/A

NOTES:

DATASHEET NOTES
N/A

INSTRUCTION NOTES
N/A