

DRAWING NUMBER:	01-2510-X-XX
PRODUCT GROUP:	BANANA PLUGS, JACKS AND PHONE TIPS
SUB-GROUP:	NON-INSULATED BANANA JACKS
DESCRIPTION:	NON-INSULATED MINIATURE BANANA PANEL JACK

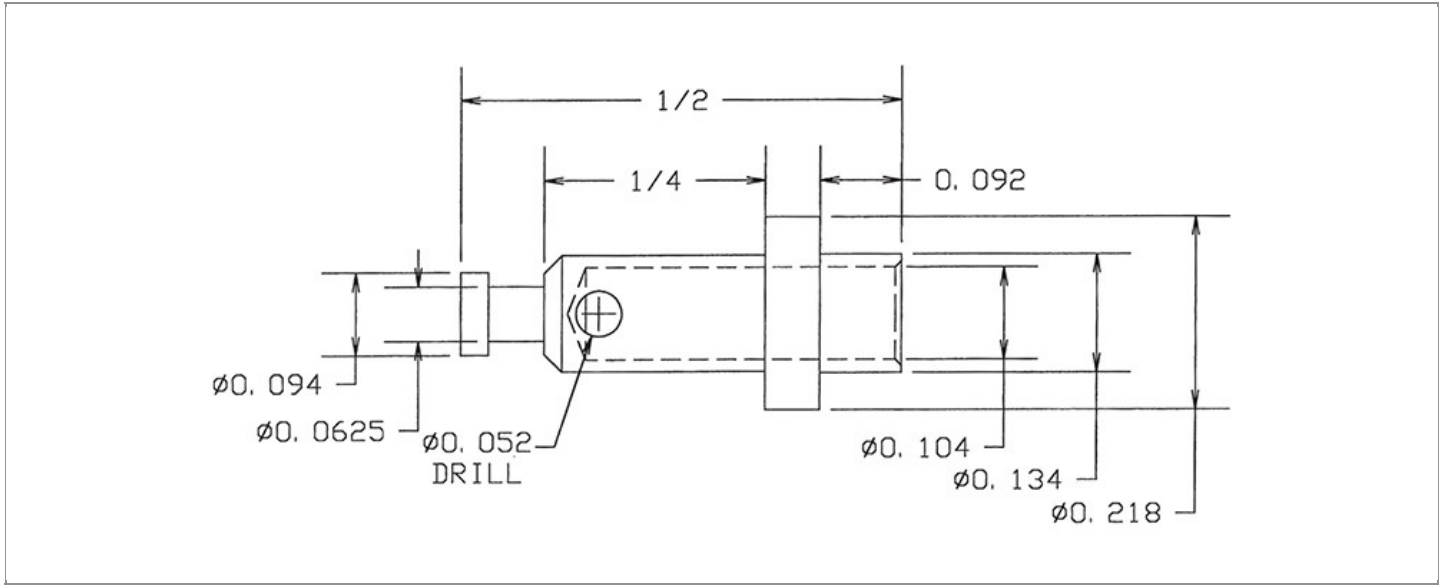

ACCEPTS PIN / PLUG / JACK SIZE	BOARD / PANEL MOUNTING METHOD	MOUNTING HOLE SIZE	DRILL SIZE
MINIATURE BANANA PLUG	SWAGE MOUNT	0.1405"	#28

PART NO. STRUCTURE:

01-2510 - 1 - XX
 PART SERIES DIMENSION FINISH

MATERIAL OPTIONS:

01-2510-1-XX

COMPONENT	MATERIAL	MATERIAL AND SPECIFICATION
BODY	BRASS	BRASS PER ASTM B16, ALLOY C36000, 1/2 HARD
NUT	N/A	N/A
LUG	N/A	N/A

DIMENSION OPTIONS:

01-2510-1-XX

DIMENSION	OVERALL LENGTH	MIN. HOLE DEPTH	SHANK LENGTH (L)	BOARD/PANEL THICKNESS
1	0.500"	0.324"	0.092"	1/16"

FINISH - PLATING OPTIONS:

01-2510-1-XX

FINISH CODE	COMPONENT	FINISH	FINISH AND SPECIFICATION
02	BODY	NICKEL	0.000100"MIN. NICKEL PER SAE-AMS-QQ-N-290
	NUT	N/A	N/A
	LUG	N/A	N/A
03	BODY	GOLD	0.000010"MIN. GOLD PER ASTM B488, TYPE II, CODE C OVER 0.000050"MIN. NICKEL PER SAE-AMS-QQ-N-290
	NUT	N/A	N/A
	LUG	N/A	N/A
044	BODY	BRIGHT ELECTRO-TIN	0.000300"MIN. BRIGHT ELECTRO-TIN PER ASTM B545 OVER 0.000100"MIN. COPPER PER SAE-AMS-2418
	NUT	N/A	N/A
	LUG	N/A	N/A

TOLERANCES:*

DECIMAL	FRACTIONAL	ANGULAR	DRAWING ORIENTATION DATE	LAST MODIFICATION DATE
± 0.010	± 1/64	± 5°	5/15/1998	4/1/2017

*All dimensions are in inches.

RoHS COMPLIANCE:

01-2510-1-XX

PART NUMBER	RoHS COMPLIANT
01-2510-1-02	YES
01-2510-1-03	YES
01-2510-1-044	YES

TOOLING:

INSTALLATION TOOL: ARBOR PRESS	INSTALLATION TOOL: ANVIL (ARBOR PRESS OPERATED)	INSTALLATION TOOL: PRESS-FIT / ROLL SWAGE / RIVET PUNCH (ARBOR PRESS OPERATED)
TM1	TA218-135-60	TP135-104

NOTES:

DATASHEET NOTES

RATED FOR 15 AMPERES CONTINUOUS DUTY. ACCEPTS MINIATURE BANANA PLUG. MOUNTS IN ROUND HOLE IN PANEL. HEAT TREATED TO FACILITATE SWAGING. LISTED MINIMUM HOLE DEPTH AFTER SWAGE INSTALLATION.

INSTRUCTION NOTES

SEE GENERAL SWAGING INSTALLATION INSTRUCTION ON CONCORD ELECTRONICS' WEBSITE WWW.CONCORD-ELECTRONICS.COM.
